

Industrial Clutch Products

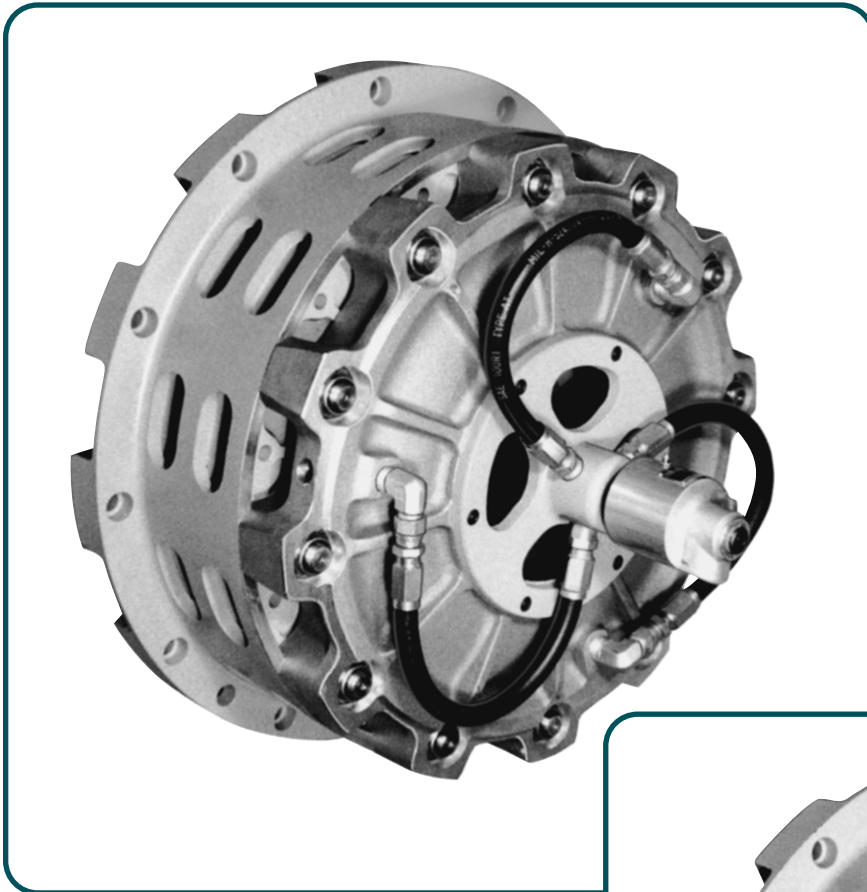

MODEL LKT

Air Set Clutches & Brakes

LKT Clutch or Brake Design Features

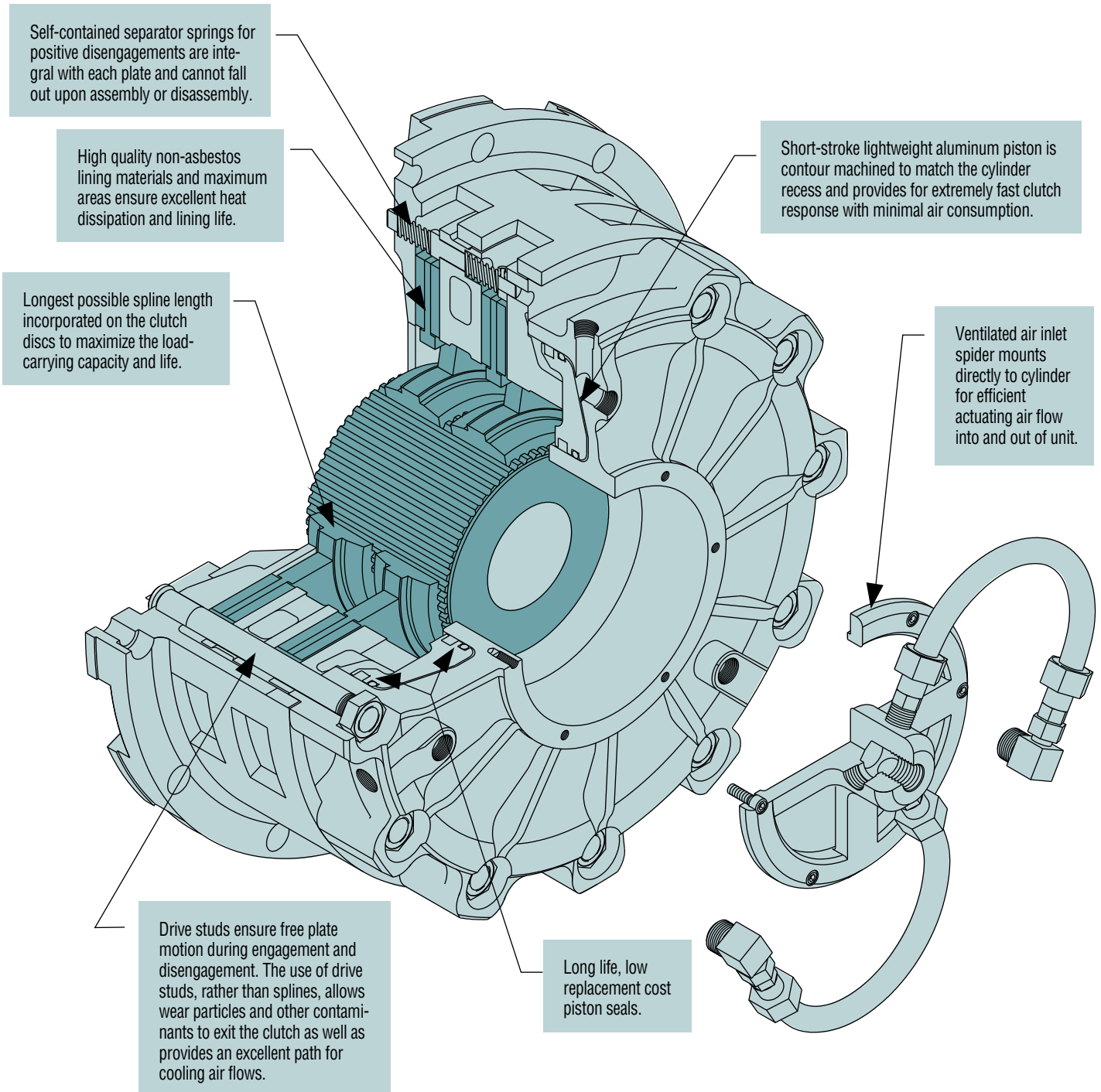

Unit has been designed with total attention given to maximizing ventilation for cool-running operation. Benefits include: longer lining life; stable friction coefficients; and lower maintenance costs.

All materials selected and field proven to provide the best available resistance to wear and thermal distress.

Precision machining of all components ensures positive interchangeability of all mating parts.

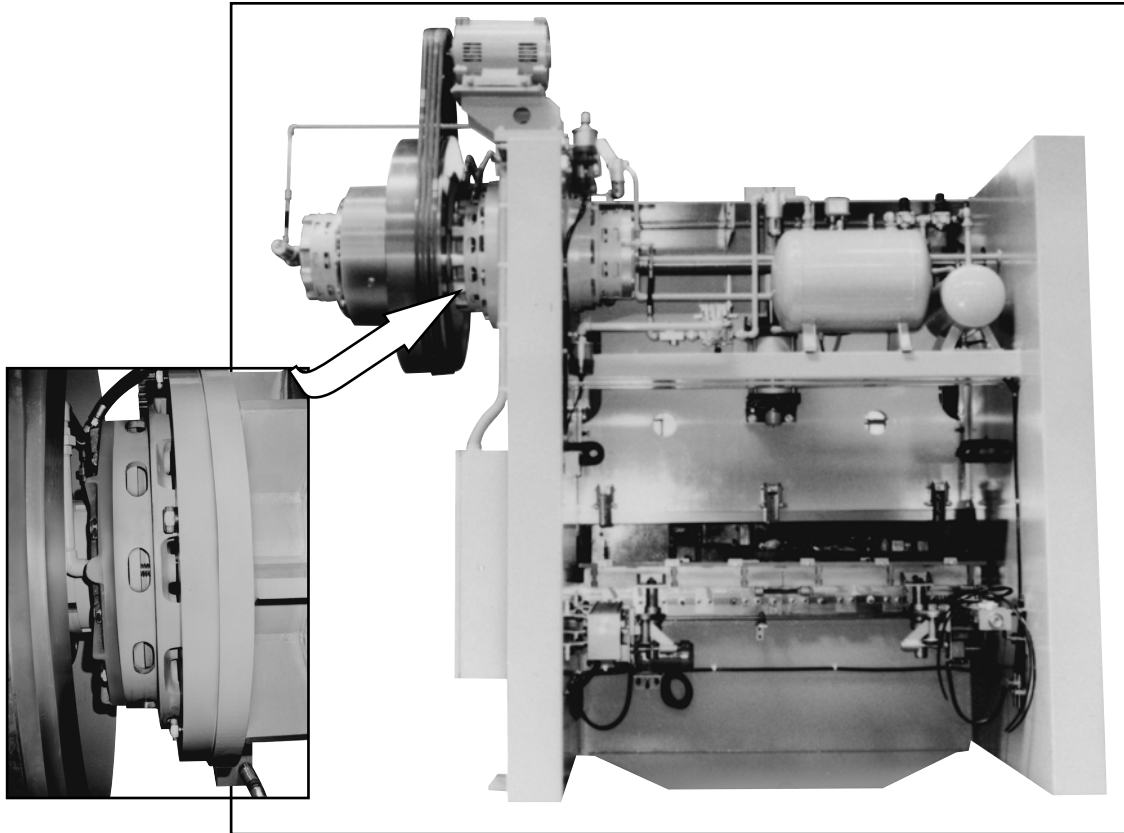

LK-121-T
 Brake installed
 on 200-ton,
 2-speed press
 brake

Photo courtesy of Kansai Iron and Sunny Ltd.

LOW INERTIA LKT CLUTCH OR BRAKE DESCRIPTION

The Model LKT clutch or brake contains identical features to the Model LK units with the exception being the cylinder piston arrangement. Whereas the Model LK unit has a full cylinder covering its entire outboard end, the Model LKT has a doughnut type cylinder which allows it to be mounted in a through-shaft arrangement as an air set brake. The design incorporates an extremely low driven inertia and the quickest response with minimal air consumption of any clutch or brake available. It is particularly suited to those applications requiring frequent cycling and long life such as is found in metal-forming or indexing applications.

The components are arranged simply and efficiently.

- A. Drive ring with integral drive studs.
- B. Lined friction discs with internal drive splines.
- C. Driving center plate with integral separating springs.
- D. Driving pressure plate with integral separating springs.
- E. Actuating piston and seals.
- F. Actuating cylinder with integral air inlet spider.
- G. Externally splined inner hub (not shown).

Whether the application is in metalforming, oilfield machinery, cranes, shovels, paper machinery or marine equipment, the LKT low inertia design is an ideal choice for through shaft mounting arrangements as an air set brake or end of shaft mounting as a clutch.

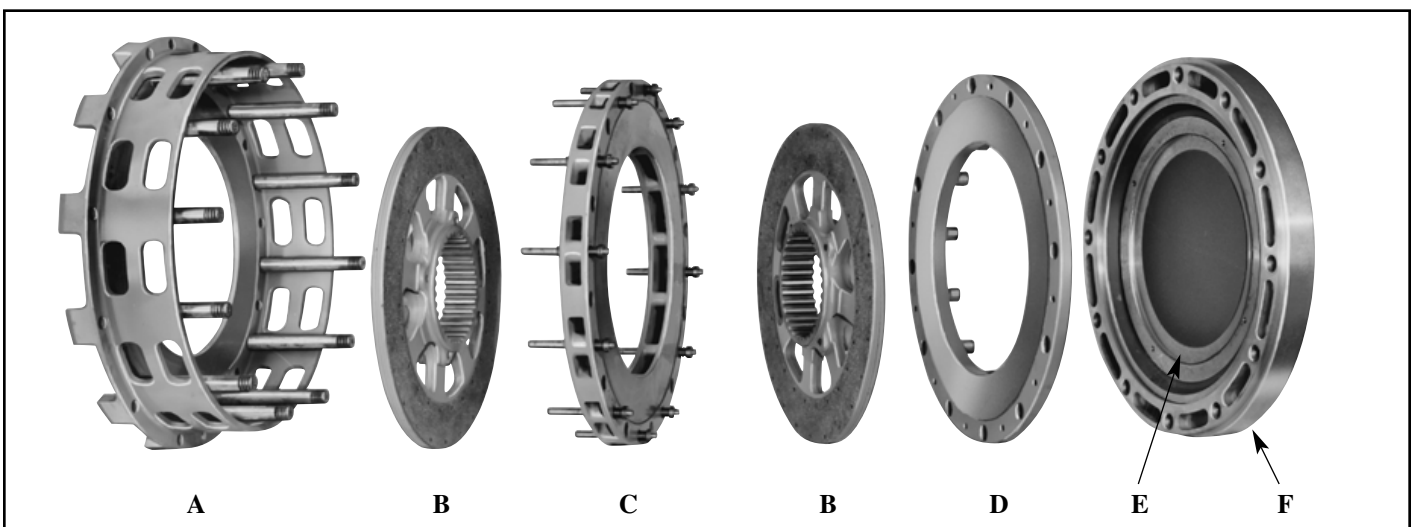

Model LKT

SINGLE DISC CLUTCH WITH ROTARY SEAL ADAPTOR PLATE

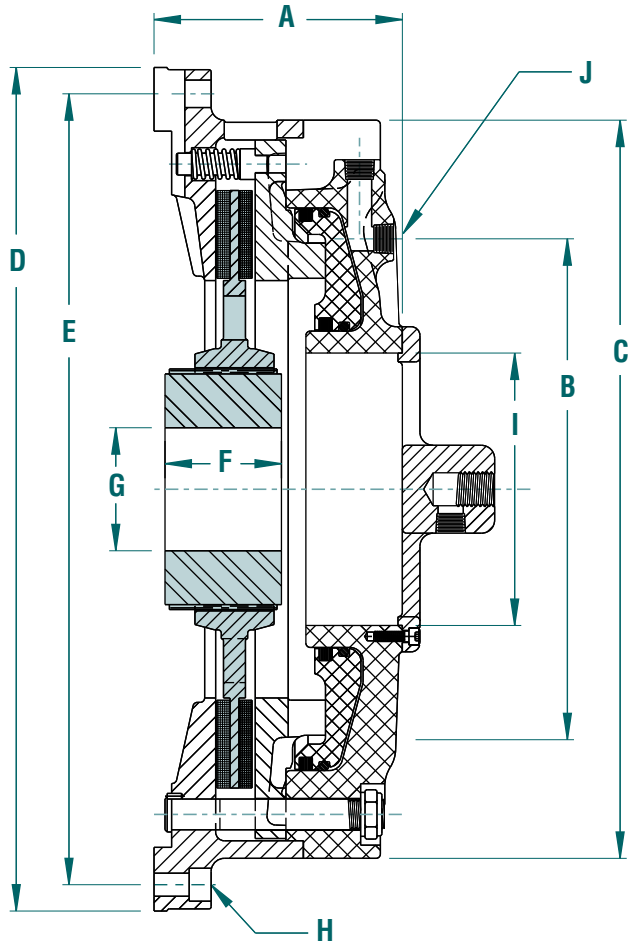

DOUBLE DISC BRAKE

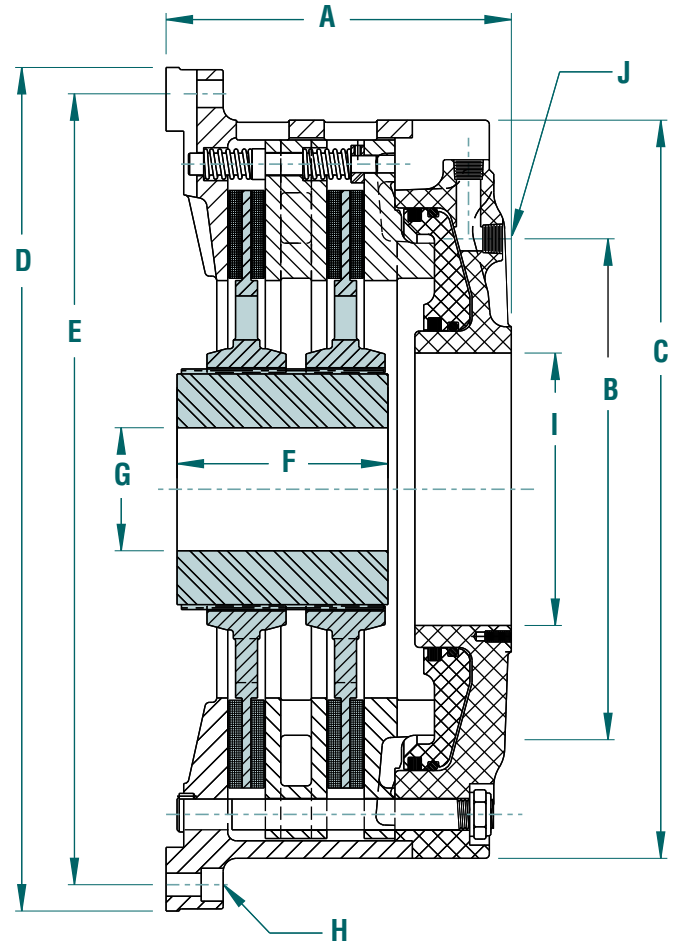

DIMENSIONAL DATA

All dimensions in inches

LKT Model	Static Torque @ 100 PSIG (lb.-in.)	Dynamic Torque @ 100 PSIG (lb.-in.)	Weight Outer (lbs.)	Weight Inner (lbs.)	Total Weight (lbs.)	WR ² Outer (lb.-ft. ²)	WR ² Inner (lb.-ft. ²)	A	B	C	D	E	F	G Min.-Max.	H No.-Size	I	J No.-Size
LKT-113	26,140	22,655	111	35	146	44.88	2.06	5.75	10.75	16.63	18.88	17.625	3.75	2-1/4 - 3-1/4	(8) - 5/8	7.00	(2) - 1
LKT-213	52,280	45,310	140	52	192	57.70	3.77	7.56	10.75	16.63	18.88	17.625	4.50	2-1/4 - 3-1/4	(8) - 5/8	7.00	(2) - 1/2
LKT-117	60,650	52,565	185	58	243	96.61	9.35	7.06	14.28	21.00	24.00	22.500	3.31	2-3/8 - 4-1/4	(12) - 5/8	7.75	(3) - 1/2
LKT-217	121,300	105,125	275	111	386	141.06	18.32	9.81	14.25	21.00	24.00	22.500	6.00	2-7/16 - 4-1/4	(12) - 5/8	7.75	(3) - 1/2
LKT-121	119,965	103,970	232	72	304	189.40	18.35	6.72	16.00	25.00	28.25	26.750	3.31	2-3/4 - 4-1/2	(12) - 3/4	9.75	(2) - 3/4
LKT-221	239,930	207,940	348	139	487	271.44	36.32	9.22	16.00	25.00	28.25	26.750	6.00	2-3/4 - 4-1/2	(12) - 3/4	9.75	(2) - 3/4
LKT-125	270,960	234,830	388	131	519	418.0	38.80	9.19	16.50	29.75	32.50	31.000	5.00	3-3/4 - 5-3/8	(12) - 3/4	6.88	(2) - 1
LKT-225	541,915	469,660	540	226	766	580.8	74.90	12.38	16.50	29.75	32.50	31.000	7.25	3-3/4 - 5-3/8	(12) - 3/4	6.88	(2) - 1
LKT-130	387,640	335,955	789	211	1,000	1050.0	90.00	12.88	20.25	35.50	39.00	37.000	5.00	4-5/8 - 7-1/2	(12) - 7/8	9.75	(2) - 1
LKT-230	775,285	671,910	1,018	356	1,374	1384.0	172.00	16.13	20.25	35.50	39.00	37.000	7.13	4-5/8 - 7-1/2	(12) - 7/8	9.75	(2) - 1

- NOTES:** 1.) Use certified drawing dimensions only for final layouts.
 2.) DXF and IGES files available upon request.
 3.) Dimensions subject to change without notice.
 4.) Consult factory or refer to application information when selecting units.